

Dimensioni di ingombro BR 02

Overall dimensions BR 02

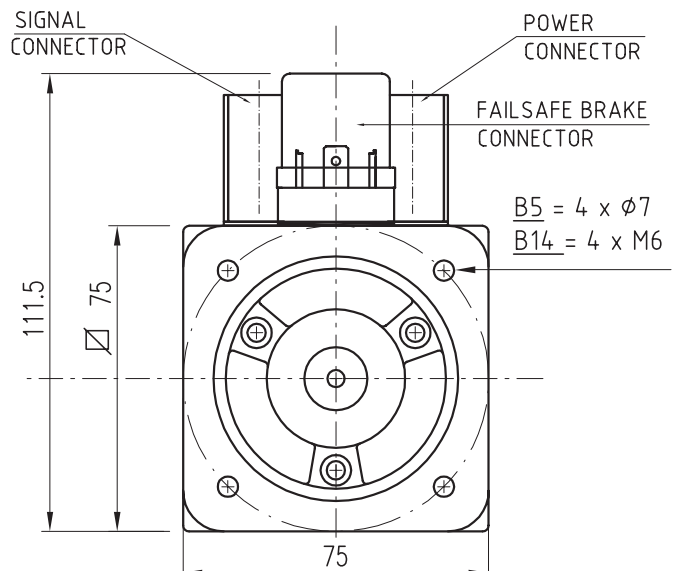
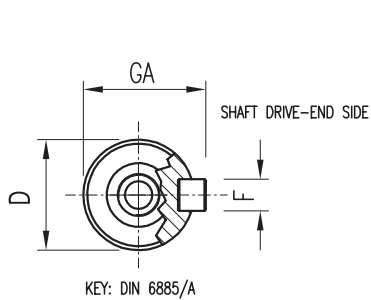
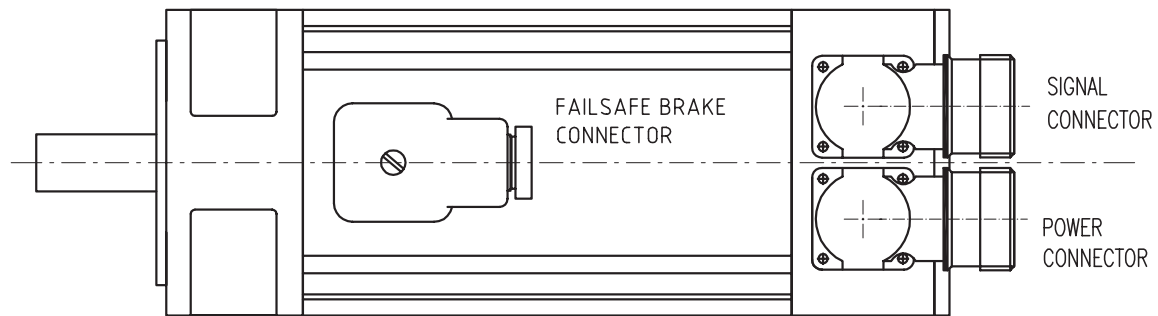
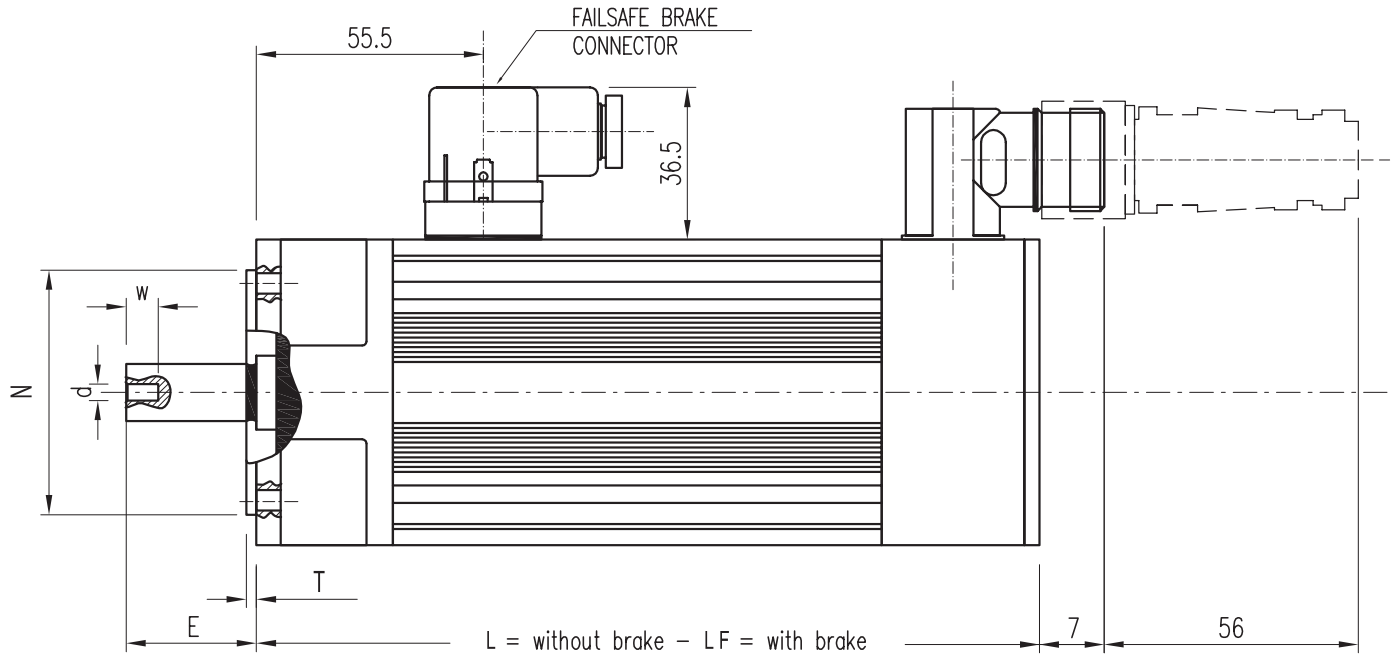

Ventilazione: Convezione Libera IC410
Cooling: Free Convection IC410

Tipo Type	Lunghezza / Length		Albero / Shaft				Flangia / Front flange			
	L	LF	D	E	GA	F	□	d x W	N	T
BR 022	155	195,5	14 j6	30	16	5	75	M5 x 15	60 j6	2,5
BR 024	185	222,5								
BR 026	215	252,5								
BR 028	245	282,5								

Motori con freno: vedere lunghezza aggiuntiva pagina 5
Motors with brake: see the additional length at page 5