

for AC Synchronous & BLDC Motors



- Compact hollowshaft motor encoder, ideal for BLDC, DC-Servo and Stepper feedback
- Incremental & commutation
- Phased Array Technology
- Up to 10000 ppr
- Frequency response to 500 kHz
- Operating temperature up to 120°C
- Through hollow shaft up to diameter 12.7 mm
- Stator coupling
- External diameter 50 mm
- Cable plug-in radial/axial

GENERAL INFORMATION

The type F18 encoder provides high performance, cost effective feedback for stepper and servo motor controls. The F18 offers compact package dimensions and a pluggable pin header. A compliant tether allows easy mounting with high tolerance to motor shaft movement and 30 degrees of adjustment to align the signal outputs to the shaft position.

A superior optical configuration allows for generous internal component clearance eliminating potential damage at high ambient operating temperatures. High temperature rated grease is standard for extended bearing life. No special tools are required for installation.

The use of optically-generated signals for Brushless DC (BLDC) servo control provides higher accuracy and reliability by eliminating the hysteresis found in competitive units with hall effect sensors, ensuring maximum performance and reliability of the servo system.

NUMBER OF PULSES

500, 512, 1000, 1024, 2000, 2048, 2500, 4096, 5000, 8192, 10000;
optional additional 4, 6, 8, 10, 12 or 16 pole commutation signals

TECHNICAL DATA
mechanical

Shaft	Through hollow shaft
Shaft diameter	6, 8, 10, 12 mm; <i>1/4", 3/8", 7/16", 1/2"</i>
Shaft tolerance	+0.025 / -0.000 mm
Moment of inertia	37.3 gcm ²
Axial endplay of mating shaft	±1.5 mm
Radial runout of mating shaft	0.05 mm (includes shaft perpendicularity)
Max. speed	(Frequency / ppr) x 60 or 12000 min ⁻¹ , whichever is less
Bearing life	(3.6 x 10 ⁹) / min ⁻¹ [hours] e.g. 605 000 hours at 6 000 min ⁻¹
Protection class	IP40 (with cover)
Operating temperature	0 ... +120 °C
Storage temperature	-40 ... +120 °C
Shock resistance	1000 m/s ² (11 ms)
Vibration resistance	25 m/s ² (5...2000 Hz)
Material housing	Aluminium

for AC Synchronous & BLDC Motors

TECHNICAL DATA electrical

Supply voltage	DC 5 V $\pm 10\%$
Max current w/o load	Max. 150 mA (incremental) Max. 175 mA (incremental +commutation)
Incremental signals	A, B
Resolution	Max. 10 000 ppr (see ordering information)
Accuracy	Incremental 2' (2 edges to any edges)
Phasing A to B	A leads B by 90° ccw (view on mounting shaft)
Phasing tolerance A to B	$\pm 45^\circ$
Max. output frequency	250 kHz up to 1 024 ppr 500 kHz > 1 024 ppr
Signal level	TTL differential (RS422)
Output current	RS 422 ± 40 mA (ET7272) NPN O.C. -16 mA (2k Ω int. pull up)
Commutation	U, V, W
Signal shape	trapezoid commutation
Phasing	U leads V leads W by 120°
Tolerance N to U	$\pm 1^\circ$ mech. index pulse center to U channel edge (see signal diagram)
Connection	16 pins double row pin header, axial or radial Mating connector with 28 AWG cable available
Reference signal	N
Index pulse width	90° (A gated B)

DIMENSIONAL DRAWINGS

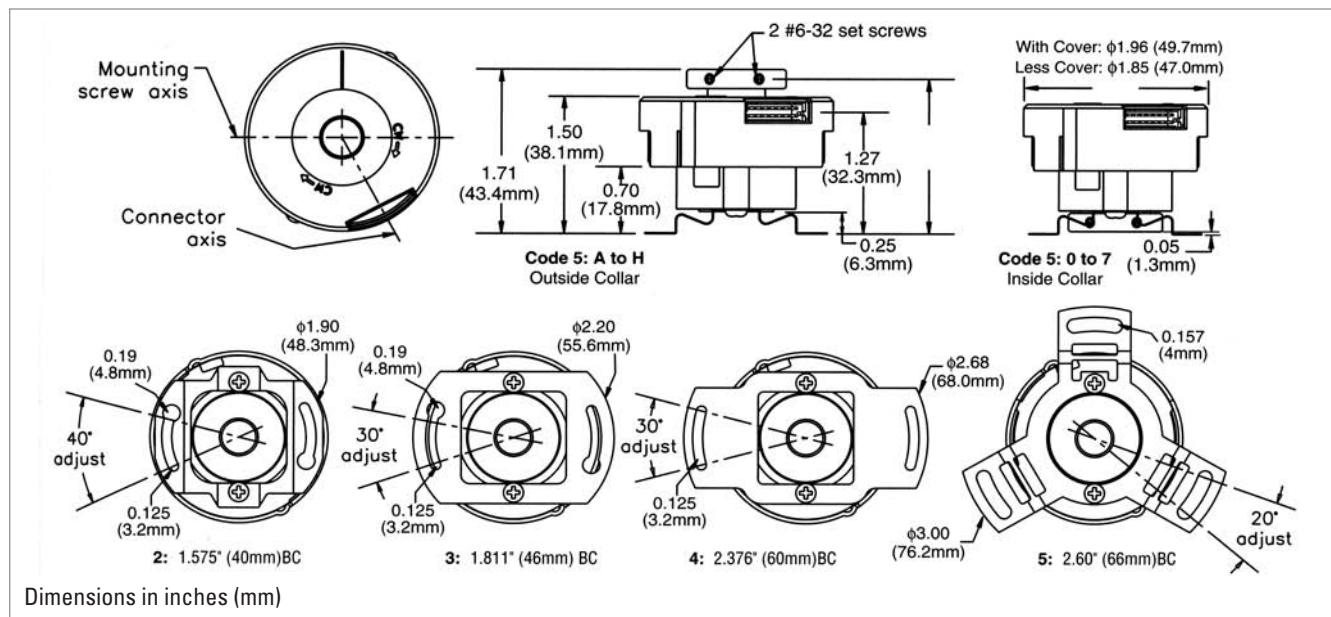

for AC Synchronous & BLDC Motors

SIGNAL DIAGRAM

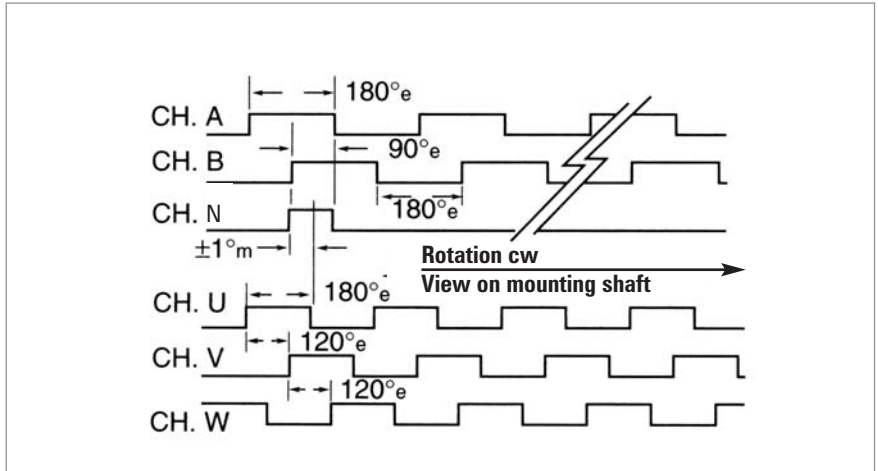

CONNECTION

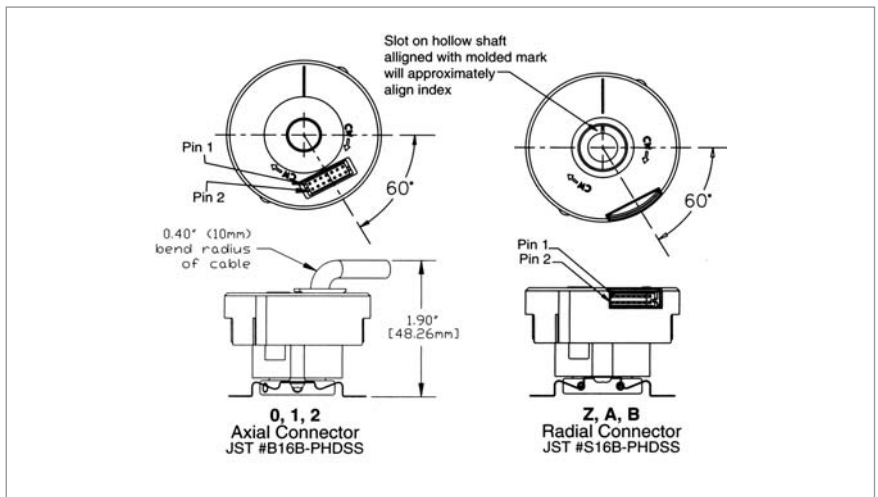

CONNECTION DIAGRAM

Pin	Function ¹	Colour
1	VCC	red
2	U	brown
3	GND	black
4	V	grey
5	A	blue
6	W	white
7	\bar{A}	blue/black
8	-	-
9	B	green
10	\bar{U}	brown/black
11	\bar{B}	green/black
12	\bar{V}	grey/black
13	N	violet
14	\bar{W}	white/black
15	\bar{N}	violet/black
16	-	-

¹ Availability of function depends on version

for AC Synchronous & BLDC Motors

ORDERING INFORMATION

Type	Pulses ppr incremental ²	Poles commutation ²	Mounting	Electrical ¹	Shaft	Connection ³
<input type="checkbox"/>	<input type="checkbox"/> / <input type="checkbox"/>	<input type="checkbox"/> - <input type="checkbox"/>	<input type="checkbox"/>	<input type="checkbox"/>	<input type="checkbox"/>	<input type="checkbox"/>
F18	0500 0512 1000 1024 2000 2048 2500 4096 5000 8192 10E3 = 10000	0 without 4 4 pole 6 6 pole 8 8 pole A 10 pole C 12 pole G 16 pole	tether 0 without tether 2 1.575" (40 mm) TK 3 1.811" (46 mm) TK 4 2.376" (60 mm) TK 5 2.60" (66 mm) TK	incremental only, < 2048/0 (ppr/poles) 0 U _{inc} =DC 5 V; output _{inc} =NPN-O.C. incremental only without commutation 3 U _{inc} =DC 5 V; output _{inc} =RS 422 incremental plus commutation signals 6 U _{inc} =DC 5 V; output _{inc} =RS 422, U _{com} =DC 5 V; output _{com} =NPN-O.C. 9 U _{inc} =DC 5 V; output _{inc} =RS 422, U _{com} =DC 5 V; output _{com} =RS 422	Clamping ring front 0 1/4" 4 6 mm 1 3/8" 5 8 mm 2 7/16" 6 10 mm 3 1/2" 7 12 mm Clamping ring rear A 1/4" E 6 mm B 3/8" F 8 mm C 7/16" G 10 mm D 1/2" H 12 mm	Axial plug 0 without cable 1 30 cm cable 2 60 cm cable Radial plug Z without cable A 30 cm cable B 60 cm cable

¹ U_{inc}: Supply voltage incremental,
U_{com}: Supply voltage commutation (only if commutation is selected)

² allowed combinations see available combinations (pulses/poles)

³ Other lengths in multiples of 30 cm, e.g. 90 cm = 3 / 90 cm = C etc.

Available combinations (pulses/poles)

Pulses ppr	Number of poles						
	0	4	6	8	10 (=A)	12 (=C)	16 (=X)
0500	X	X	X	X	X	X	
0512	X	X	X	X			
1000	X	X	X	X	X	X	
1024	X	X	X	X		X	
2000	X	X	X	X	X	X	
2048	X	X	X	X	X	X	X
2500	X	X	X	X	X	X	
4096	X	X	X	X	X	X	X
5000	X	X	X	X	X	X	
8192	X	X	X	X	X	X	X
10E3 = 10000	X	X	X	X	X	X	